



8X36

DAYTIME BINOCULARS

USER MANUAL

© 2021 AGM Global Vision, LLC. All rights reserved.

This documentation is subject to change without notice.

No parts of this manual, in whole or in part, may be copied, photocopied, translated, or transmitted by any electronic medium or in machine-readable form without the prior written permission of AGM Global Vision, LLC.

If you have questions that are not covered in this manual, or need service, contact AGM Global Vision customer support for additional information prior to returning a product.

AGM Global Vision, LLC

173 West Main Street

PO Box 962

Springerville, AZ 85938

Tel. 928.333.4300

support@agmglobalvision.com

www.agmglobalvision.com

LIST OF CONTENTS

TITLE	PAGE
Safety Summary	4
SECTION 1. DESCRIPTION AND DATA	5
1.1 System Description	5
1.2 Key Features	5
SECTION 2. OPERATING INSTRUCTIONS	6
2.1 Parts and Controls of Binoculars	6
2.2 Interpupillary Adjustment	7
2.3 Diopter Adjustment	7
2.4 Reticle Using	8
2.5 Fold-Down Eyecups Using	11
2.6 Tripod Mounting	11
SECTION 3. MAINTENANCE	12
3.1 General Maintenance	12
3.2 Storage	12
3.3 Service and Maintenance	12
SECTION 4. WARRANTY INFORMATION	13
4.1 Warranty Information and Registration	13
SECTION 5. SPECIFICATIONS	15

SAFETY SUMMARY

- Read and follow all instructions
- Read all warnings
- Only use the attachments/accessories specified by the manufacturer
- All service must be provided by the manufacturer

WARNING:

This product contains natural rubber latex which may cause allergic reactions! The FDA has reported an increase in the number of deaths that are associated with an apparent sensitivity to natural latex proteins. If you are allergic to latex, it is a good idea to learn which products contain it and strictly avoid exposure to those products.

WARNING:

Do not watch the sun directly by using binoculars to avoid harming your eyes.

CAUTION:

- The binoculars are a precision optical instrument, and must be handled carefully at all times to prevent damage to the device.
- The unit may be badly damaged if the tripod on which it is mounted collapses or overturns. Remove the unit from the tripod if it is not within your reach.
- Do not turn the diopter adjustment handwheel in overexerting, stop to turn when it reach the limited position, otherwise the eyepieces assembly will be damaged!
- Be careful to move the binoculars to avoid overexertion or collision.
- To avoid the heavy vibration when you take it.
- Thoroughly dry each component of the binoculars before placing them in the storage case.

NOTES:

For the purpose of returning defective components, retain all packaging materials.

1 DESCRIPTION AND DATA

1.1 SYSTEM DESCRIPTION

The AGM 8x36 daytime binoculars that offers plenty of magnification, waterproof construction, built-in range finder reticle purposed for military, law enforcement or an outdoor adventurer's needs.

The AGM binoculars provides a powerful magnification and crystal-clear optics, that deliver a full range of color and clarity. The multicoated optics of binoculars is designed to enhance the resolution and contrast of your image in extremely bright conditions.

Built-in universal range finder allows for accurate target measurements and range estimates.

The AGM binoculars are waterproof and shockproof and can reach the standard of GJB/240, GJB150 and MIL-STD-810.

1.2 KEY FEATURES

- **Powerful magnification**
- **Designed for professional use**
- **Built-in universal rangefinder**
- **Multicoated optics**
- **Full rubber body armoring**
- **Individual eye focus**
- **Limited two-year warranty**

2 OPERATING INSTRUCTIONS

WARNINGS:

Do not watch the sun directly by using binoculars to avoid harming your eyes.

2.1 PARTS AND CONTROLS OF BINOCULARS

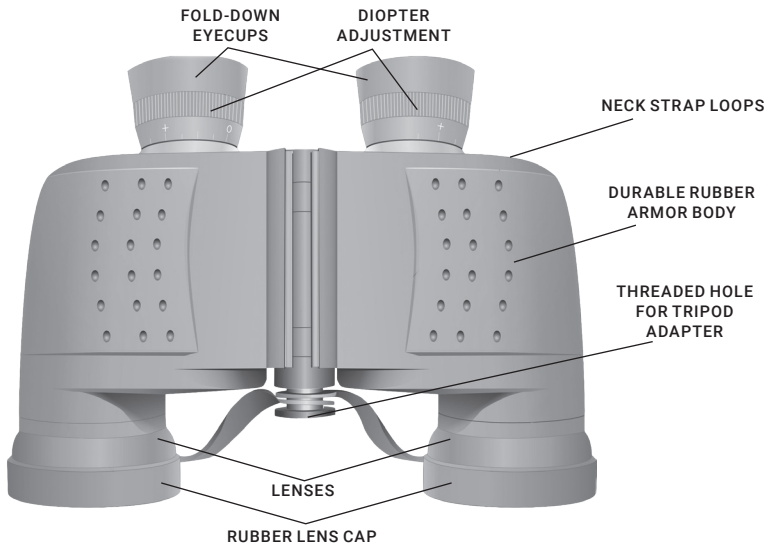

FIGURE 1. PARTS AND CONTROLS OF BINOCULARS

2.2 INTERPUPILLARY ADJUSTMENT

You must first adjust the binoculars so that each eye piece is adjusted to the distance between your eyes. This is done by putting the binoculars in both hands and bending it until you can see a single circular image.

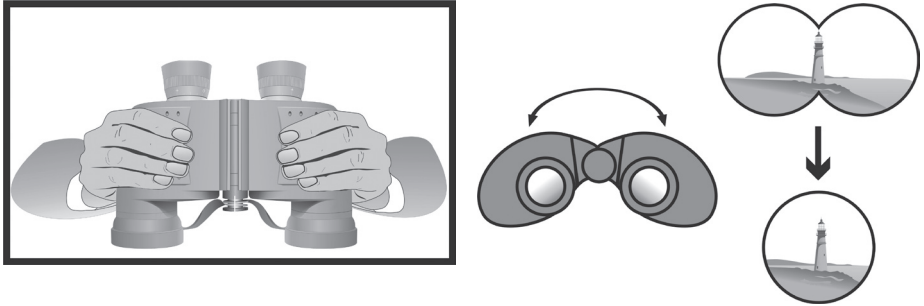

FIGURE 2. INTERPUPILLARY ADJUSTMENT

2.3 DIOPTER ADJUSTMENT

To watch the object by handing the binoculars, you will need to close your left eye. Rotate the right diopter adjustment rings until the object image appears sharp and clear in your right eye opening. Then open you left eye and close right eye, rotate the left diopter adjustment rings until the object image appears sharp and clear in your left eye opening. Then can get a perfect viewing.

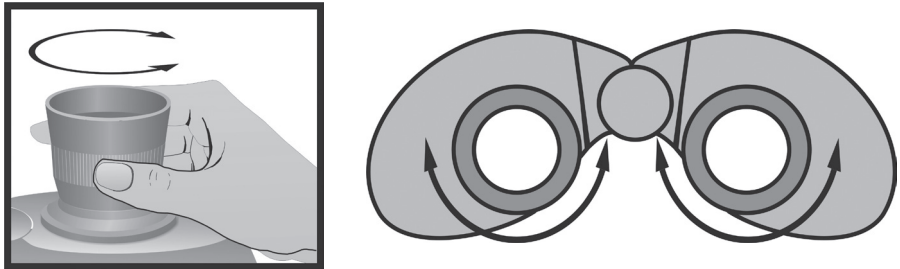

FIGURE 3. DIOPTER ADJUSTMENT

2.4 RETICLE USING

2.4.1 BINOCULARS RANGEFINDER RETICLES

The reticle has horizontal scale and vertical scale, in the below there is measuring reticule according to the known height (see Figure 4). Vertical and horizontal lines on the reticule is in mils as unit. Each small division on both vertical and horizontal lines represents 5 mils and each big division represents 10 mils. You can obtain the azimuth angle, upper and lower angle, distance and height or width etc. by using this reticule. The fast distance measurement is regards as the target as 2 meters high to measure the distance quickly.

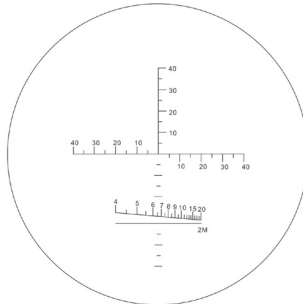

FIGURE 4. 8X36 RETICLE

2.4.2 HOW TO USE THE RETICLE AND CALCULATOR DIAL

1) How to Measure the Horizontal View Angle

The azimuth angles are the angle included between two objects to be measured at the horizontal direction of the binoculars.

A. When the Horizontal View Angle is smaller than the horizontal scale range (-40~+40 mils) inside the binoculars, aim one edge of the object at a horizontal scale line (the center or the outmost line are selected according to the image size of object usually) and read its value. Then read the value of the scale at which another edge was located. Add these two values, the sum value is the measured Horizontal View Angle. As shown in Figure 5, the Horizontal View Angle of the target (tank) is 20-00 mils, and the Horizontal View Angle is 20 mils.

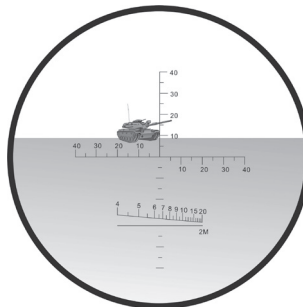

FIGURE 5. HORIZONTAL VIEW ANGLE MEASURING

B. When the Horizontal View Angle is bigger than the horizontal scale range (-40~+40 mils), a vertical line splits(for example: mast, chimney etc.) on the object can be selected to make the necessary estimated measurements in a step by step fashion. The sum of the value from each step is used to obtain the measured value. As shown in Figure 6, the azimuth of target (cruiser) is 110 mils (60+50=110).

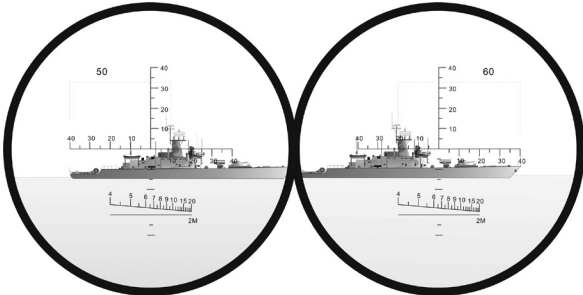

FIGURE 6. MEASURING OF BIG VIEW ANGLE

2) How to Measure the Vertical View Angle

Upper and lower angle means the angel included between any two targets (or two ends of the target) against the vertical line on the reticle.

A. Vertical View Angle measurement is similar to measuring the Horizontal View Angle. When the Vertical View Angle measurement is small, aim the cross center of reticle at lower part of the object, read the scale value at the top of the object. If the target vertical angle is a little bigger, you can read the upper scale and the lower scale. As shown in Figure 7, the upper line is 35 mils, and the lower line is 40 mils, the total vertical angle is 75 mils.

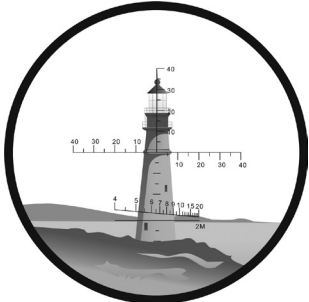

FIGURE 7. VERTICAL VIEW ANGLE MEASURING

B. When the Vertical View Angle is larger than the vertical scale range (-40 to +40 mils), it can be measured in steps and the angle can be obtained by summing up the value of each step. (The process will be similar to the measurements as mentioned above as horizontal view angle.)

3) How to Use the Reticle to Measure Distance.

The distance measurement of a target can be calculated by using the mil reticule.

The formula of distance measurement: $L(\text{km}) = H(\text{m}) / \omega$

L – the distance between the observer and the object (km)

H – the height of the object (m)

ω – the view angle of the object measured with the reticule of binoculars (mil).

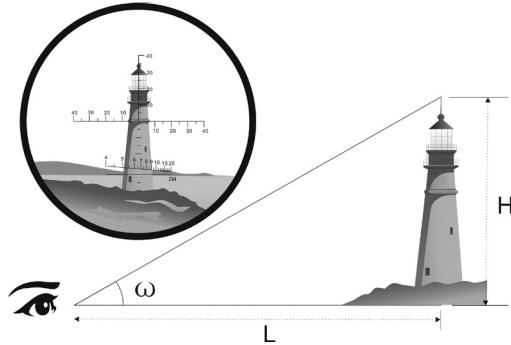

FIGURE 8. DISTANCE MEASURING

When measure the distance, first, estimate the width or height of the object, then measure the View Angle of the object. According, you can calculate the distance between the observer and the object using the formula.

For example 1:

There is a lighthouse height is 25 m ($H = 25$ m).

The Vertical View Angle of the adult is 6 decade mils (60 mils).

$$L = H / \omega = 25 / 60 = 0.4166 \text{ km} = 416.6 \text{ m}$$

Therefore: the distance between the observer and the adult is 416.6 m.

For example 2:

There is an adult whose height is 1.70m ($H = 1.70$ m).

The Vertical View Angle of the adult is 4 decade mils (40 mils).

$$L = H / \omega = 1.7 / 40 = 0.0425 \text{ km} = 42.5 \text{ m}$$

Therefore: the distance between the observer and the adult is 42.5 m.

4) How to Measure an Object's Size (Height and Width) Using

According to the formula for distance measurement, you can calculate the height using:

$$H = L \times \omega.$$

When measuring the size, you first estimate the distance to the object, then measure the View Angle. With these measurements, you can calculate the height of the target using the formula.

For example:

The distance is 0.6 km between the observer and the object. You can measure that the Horizontal View Angle is 6 decade mils (60mils) and the Vertical View Angle is 3 decade (30 mils). So, using the formula you can get:

$$\text{The height: } H = 0.6 \times 30 = 18 \text{ m}$$

$$\text{The width: } h = 0.6 \times 60 = 36 \text{ m}$$

5) Quick Distance Measurement

The reticle is consisted of one horizontal line and a diagonal line. And regards the H=2 m as known height to quickly measure the common target such as vehicle or adult. Placing the target projection between the 2 lines, the reading on the tangency of the projection and diagonal line is the target distance (line value:100 m). as shown in Figure 9, the distance between the target in 2 m high and the observer is 550 m.

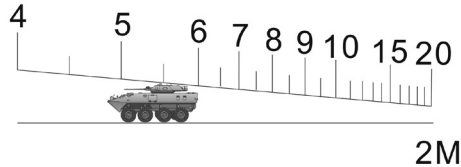

FIGURE 9. QUICK DISTANCE MEASUREMENT

2.5 FOLD-DOWN EYECUPS USING

AGM Binoculars designed with rubber fold-down eyecups. The fold-down eyecups can help when wearing gas mask or glass.

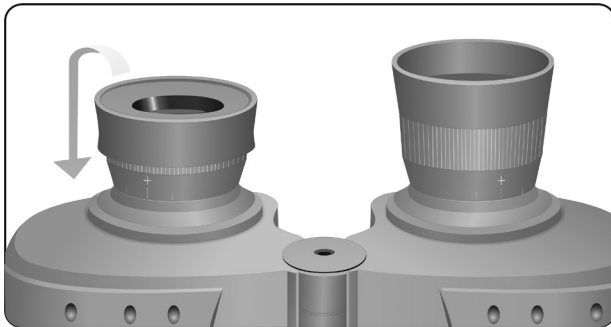

FIGURE 17. FOLD-DOWN EYECUPS

2.6 TRIPOD MOUNTING

A standard threaded socket in 1/4 inch for tripod attachment is located at the base of binoculars shaft. Insert a binoculars tripod adapter, and attach your tripod screw to the base of the adapter.

3 MAINTENANCE

3.1 GENERAL MAINTENANCE

Do not touch the lens by hand, be careful to protect the lens not to be injured by hard substance.

Please fold the Interpupillary adjustment in lowness, put on the lens cover and put into the soft bag when you do not use it.

Dust, salt and the oil left from fingerprint smudges should never be allowed to remain on the lenses because they can harm the sensitive multi-coatings applied to the lens surfaces.

Loose dust and debris should be removed by blowing the debris off, using an optical lens cleaning brush or compressed air.

If fingerprints or smudges remain on the lens, use an optical lens tissue and lens cleaner solution to clean the lenses. Follow the instructions on the lens cleaning tissue and cleaner.

Once the lens polluted by oil, please use the soft cotton cloth or silk to clear it with a little industrial alcohol.

3.2 STORAGE

Please put in the dryness place when you do not use it in long time. Suggest using dryer and be away from ferromagnetism material.

3.3 SERVICE AND MAINTAIN

Do not take down and maintain yourself when the binoculars can not work properly, please send back to the factory or find the service center.

4 WARRANTY INFORMATION

4.1 WARRANTY INFORMATION AND REGISTRATION

4.1.1 WARRANTY INFORMATION

This product is guaranteed to be free from manufacturing defects in material and workmanship under normal use for a period of three (3) years from the date of purchase. In the event that a defect covered by the warranty below occurs during the applicable period stated above, AGM Global Vision, at its discretion, will either repair or replace the product; such action on the part of AGM Global Vision shall be the full extent of AGM Global Vision's liability, and the Customer's sole and exclusive repairation. This warranty does not cover a product if it has been (a) used in ways other than its normal and customary manner; (b) subjected to misuse; (c) subjected to alterations, modifications or repairs by the Customer or by any party other than AGM Global Vision without prior written consent of AGM Global Vision; (d) is the result of a special order or categorized as "close-out" merchandise or merchandise sold "as-is" by either AGM Global Vision or the AGM Global Vision dealer; or (e) merchandise that has been discontinued by the manufacturer and either parts or replacement units are not available due to reasons beyond the control of AGM Global Vision. AGM Global Vision shall not be responsible for any defects or damage that in AGM Global Vision's view are a result from the mishandling, abuse, misuse, improper storage or improper operation of the device, including use in conjunction with equipment that is electrically or mechanically incompatible with, or of inferior quality to, the product, as well as failure to maintain the environmental conditions specified by the manufacturer. This warranty is extended only to the original purchaser. Any breach of this warranty shall be enforced unless the customer notifies AGM Global Vision at the address noted below within the applicable warranty period.

The customer understands and agrees that except for the foregoing warranty, no other warranties written or oral, statutory, expressed or implied, including any implied warranty of merchantability or fitness for a particular purpose, shall apply to the product. All such implied warranties are hereby and expressly disclaimed.

4.1.2 LIMITATION OF LIABILITY

AGM Global Vision will not be liable for any claims, actions, suits, proceedings, costs, expenses, damages, or liabilities arising out of the use of this product. Operation and use of the product are the sole responsibility of the Customer. AGM Global Vision's sole undertaking is limited to providing the products and services outlined herein in accordance with the terms and conditions of this Agreement. The provision of products sold and services performed by AGM Global Vision to the Customer shall not be interpreted, construed, or regarded, either expressly or implied, as being for the benefit of or creating any obligation toward any third party of legal entity outside AGM Global Vision and the Customer; AGM Global Vision's obligations under this Agreement extend solely to the Customer. AGM Global Vision's liability hereunder for damages, regardless of the form or action, shall not exceed the fees or other charges paid to AGM Global Vision by the customer or customer's dealer. AGM Global Vision shall not, in any event, be liable for special, indirect, incidental, or consequential damages, including, but not limited to, lost income, lost revenue, or lost profit, whether such damages were foreseeable or not at the time of purchase, and whether or not such damages arise out of a breach of warranty, a breach of agreement, negligence, strict liability, or any other theory of liability.

4.1.3 PRODUCT REGISTRATION

In order to validate the warranty on your product, the customer must complete and submit AGM Global Vision PRODUCT REGISTRATION FORM on our website (www.agmglobalvision.com/customer-support).

4.1.4 OBTAINING WARRANTY SERVICE

To obtain warranty service on your unit, the End-user (Customer) must notify the AGM Global Vision service department via e-mail. Send any requests to support@agmglobalvision.com to receive a Return Merchandise Authorization number (RMA). When returning any device, please take the product to your retailer, or send the product, postage paid and with a copy of your sales receipt, to AGM Global Vision's service center at the address listed above. All merchandise must be fully insured with the correct postage; AGM Global Vision will not be responsible for improper postage or merchandise that becomes lost or damaged during shipment. When sending product back, please clearly write the RMA# on the outside of the shipping box. Please include a letter that indicates your RMA#, the Customer's Name, a Return Address, reason for the return, contact information (valid telephone numbers and/or an e-mail address), and proof of purchase that will help us to establish the valid start date of the warranty. Product merchandise returns that do not have an RMA# listed may be refused, or a significant delay in processing may occur. Estimated Warranty service time is 10-20 business days. The End-user/Customer is responsible for postage to AGM Global Vision for warranty service. AGM Global Vision will cover return postage/shipping after warranty repair to the End-user/Customer only if the product is covered by the aforementioned warranty. AGM Global Vision will return the product after warranty service by domestic UPS Ground service and/or domestic mail. Should any other requested, required, or international shipping methods be necessary, the postage/shipping fee will be the responsibility of the End-user/Customer.

For service, repair or replacement, please contact:

AGM Global Vision, LLC

173 West Main Street

PO Box 962

Springerville, AZ 85938

Tel. 928.333.4300

support@agmglobalvision.com

www.agmglobalvision.com

5 SPECIFICATIONS

5.1 SPECIFICATIONS

ITEM	DATA
Magnification	8x
Prisms system	Porro / Bak-4
Number of Elements & Groups	6 pieces in 4 groups
Objective lens diameter	35 mm
FOV (angular)	7°
FOV at 1000 m / 1000 yd	123 m / 369 ft
Minimum Focus Distance	8 m
Exit pupil	4.4 mm
Eye relief	16.2 mm
Relative Brightness	19.4
Twilight Factor	16.8
Resolution	≤ 6.2"
Focus System	Individual
Diopter Adjustment	-5 to +5 dpt
Interpupillary Distance	56 to 72 mm
Eye Cups Type	Fold down Eyecups
Body Housing Material	Strengthened PVC
Waterproof	1 m for 30 min
Nitrogen Filled	Yes
Weight	0.6 kg (3.0 lbs)
Size	165 × 127 × 65 mm (7.9 × 5.9 × 3.3 in)
Tripod mount	Yes

NOTE:

All data subject to change without notice.



AGM Global Vision, LLC

MAIN OFFICE

173 West Main Street

PO Box 962

Springerville, AZ 85938

USA

Tel. +1.928.333.4300

info@agmglobalvision.com

www.agmglobalvision.com

EUROPEAN OFFICE

Andrey Lyapchev #7

Sofia, P.C. 1756

Bulgaria

Tel. +35.988.412.5573

info@agmglobalvision.eu

www.agmglobalvision.eu

AGMglobalvision.com